

# BETTER HOME PRODUCTS

## 300 SERIES HYDRAULIC DOOR CLOSERS



Lifetime Mechanical Warranty and 5 Year Finish Warranty



- \* Heavy Duty Full Feature Commercial Door Closer for Commercial and Institutional Application
- \* Precision Heavy Duty Rack & Pinion Gear. Needle Bearing
- \* Adjustable Power Size 1 thru 6. Factory Preset Power Size 3
- \* ANSI 156.4 Grade 1. UL 10C 3 Hour Fire Rated
- \* Barrier Free. Lower Opening Resistance for the Handicapped or Elderly
- \* Full Plastic Cover Standard. SN & CH Finish Metal Cover Optional
- \* Packed With Full Set of Sex Bolts and Parallel Arm Bracket



### ITEM NUMBERS:

- DC316BCDASN - Satin Nickel (Aluminum) Finish With Plastic Cover
- DC316BCDABLK - Matte Black Finish With Plastic Cover
- DC316BCDASSSN - Satin Nickel Finish With Metal Cover
- DC316BCDASSCH - Chrome Finish With Metal Cover

### FEATURES

- \* Universal Application. Non-Handed for Standard, Top Jamb or Parallel Arm Installation
- \* Standard Adjustable Back-Check Function (BC)
- \* Standard Adjustable Delayed Action Function (DA)
- \* Adjustable Closing and Latching Speed by Two Separate Regulating Valves
- \* Barrier Free. Meets ADA Regulations
- \* For Use on Metal, Wood or Fiberglass Doors
- \* Door Weight Range from 30 - 260 Lbs

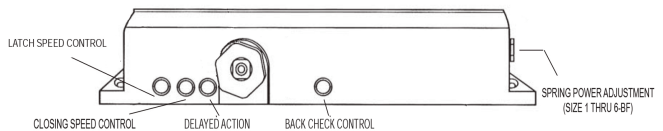
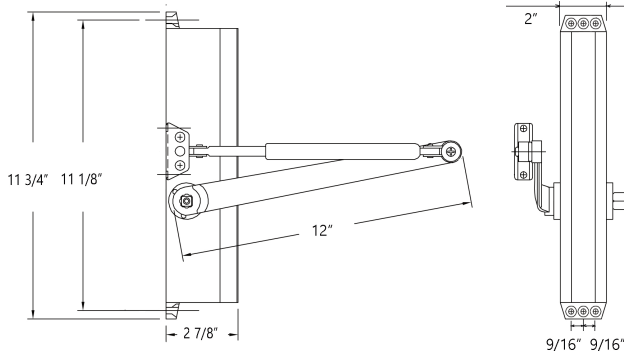

### CLOSER ADJUSTMENT

### CROSS REFERENCE

BHP	CALROYAL	NORTON	YALE	DORMA	LCN
300	900	8501	3501	8600FC	1460FC